



Halogen Exam Light III



Halogen Exam Light III with Fiberoptic Light Pipe

Model #'s - 48700, 48722, 48724, 48726, 48728

Halogen Exam Light III with Fiberoptic Light Cable

Model #'s - 48780, 48782, 48784, 48786, 48788

Halogen Exam Light III with Neonate Light Pipe

Model #'s - 48760, 48762, 48764, 48766, 48768

Halogen Exam Light III Light Box with Power Cord

Model #'s - 48740, 48742, 48744, 48746, 48748

INTRODUCTION

Thank you for purchasing the Welch Allyn Halogen Exam Light III. We believe that it is the highest quality product of its kind available in the world today. By following the simple guidelines found within this manual, you should be rewarded with years of dependable, trouble free performance. If you have any questions or concerns please feel free to contact our customer or technical service departments at (800) 535-6663 during normal business hours.

Welch Allyn remains committed to providing innovative, quality diagnostic products for healthcare professionals. Call us at (800) 535-6663 to request a full line product catalog or visit us at our Web Site, www.WelchAllyn.com.

SYMBOL DESCRIPTIONS



Attention: Consult user's manual for additional information.



Warning: Risk of fire. Replace fuses as marked.



Caution: High Temperatures



Caution: High Intensity Light

WARNINGS & CAUTIONS



WARNING: The user of this equipment should be thoroughly trained in the medical procedures appropriate to the utilization of this instrumentation. Furthermore, time should be taken to read and understand the instructions contained within this manual prior to use of this product. Instructions for other equipment used in conjunction with the Exam Light III (for example: suction machines, electrosurgical generators, etc.) should also be read and understood. Failure to understand the operating requirements for this product may result in injury to yourself, the patient and/or may damage the instrument.



CAUTION: Electric Shock Hazard - Remove power cord from electrical outlet and allow lamp to cool before replacing (Welch Allyn lamp # 04200).



DANGER: Risk of explosion if used in the presence of flammable anesthetics.



CAUTION: Federal Law restricts this device to sale by or on the order of a physician.



CAUTION: Illumination is intense - Do not stare at the light source in operation. May be harmful to eyes.



CAUTION: Use the examination light in its intended working range of 12 to 24 inches. Exposures at closer distances may be harmful to skin.



WARNING: Do not perform neonatal trans-illumination without the use of the #48210 neonatal trans-illuminator (with U.V. filter). Do not remove the focusing sleeve from the light pipe and use the light pipe for trans-illumination. Severe burns may result.

General practices to minimize risk of harm to the skin from optical radiation hazards include: minimizing illumination intensity at the tissue examination site, minimizing exposure times, and taking additional precautions when skin sensitivity has been altered through tissue trauma or the use of anesthesia.

General good practices to minimize risk of harm to the eyes from optical radiation hazards include: avoid looking at bright light sources and their reflections, and protect eyes where normal pupil sizes and aversion responses are not present.



There are no user serviceable/replaceable parts other than lamp and fuses. Please refer any other service to qualified and authorized service centers.

COMPONENTS

Standard



Light Box, Power Cord and Wall Mount

Model 48740 (Domestic)
Model 48742 (Europe)
Model 48744 (UK)
Model 48746 (Australia)
Model 48748 (Japan)



Fiberoptic Light Pipe (shown with focusing sleeve)

Model 48200
(Included only with Model #'s 48700, 48722, 48724, 48726, and 48728)



Fiberoptic Light Cable (shown with focusing sleeve)

Model 48220
(Included only with Model #'s 48780, 48782, 48784, 48786, and 48788)



Neonatal Transilluminator

Model 48210
(Included only with Model #'s 48760, 48762, 48764, 48766, and 48768)



Focusing Sleeve

Model 48605
(Included only with Model #'s 48700, 48722, 48724, 48726, 48728, 48780, 48782, 48784, 48786, and 48788)

Accessories



Fiberoptic Light Pipe (Shown with Focusing Sleeve)
Model 48200



Fiberoptic Light Cable (Shown with Focusing Sleeve)
Model 48220

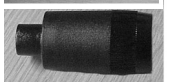

Focusing Sleeve
Model 48605



Neonatal Transilluminator
Model 48210

The optional neonatal Light Pipe/transilluminator is used to assist in the diagnosis of pneumothorax, to locate blood vessels, etc. This transilluminator incorporates a permanently attached ultraviolet filter that minimizes the transmission of ultraviolet light. The standard Fiberoptic Light Pipe or Fiberoptic Light Cable should **NOT** be used for transillumination of neonates.

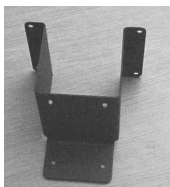

Table Mount Bracket
Model 48859



Mobile Stand
Model 48850



Disposable Sheaths
Model 52640



Disposable Sheath Dispenser
Model 52641



35W Halogen Replacement Lamp
Model 04200

MOUNTING

Use one of the following three mounting options in order to ensure proper operation of the light box.

Wall Mount

Choose appropriate mounting location. The length of the light pipe is 4 feet totally extended (fiberoptic light cable is 7.5 feet). When choosing a mounting location, keep these dimensions in mind in addition to accounting for the actual application the light will be used for and what portion of the examination table will need to be accessed.

- Using the mounting plate as a template, mark drilling holes as needed (depending on your wall type).
 - Dry Wall, Paneling, Plywood or Plaster (1/8 inch (.3 cm) to 5/8 inch (1.6 cm) thick) - drill four (4) 3/8 inch (1cm) holes, insert hollow metal wall anchor assembly.
 - Concrete Block - drill four (4) 3/16 inch (.5 cm) holes, insert plastic anchors. Use #8 x 1/2 inch screws to secure.
 - Metal Panel or Plywood walls greater than 5/8 inch (1.60 cm) thick - drill four (4) 1/8 inch (.3 cm) holes. Use #8 x 1 inch screws to secure.
- Once holes are drilled, install the mounting plate with the appropriate screws. Completely tighten the screw so there is no gap between the screw head and the mounting plate.
- Mount the Light Box to the plate by inserting the pins on the back of the light box into the slots on the mounting plate. Let the light box drop down to position the pins into the narrow portion of the mounting slots **(A)**.
- To secure the Light Box to the plate, insert two (2) .50" (1.27cm) screws through the bottom of the mounting plate and tighten into the bottom of the Light Box using a phillips head screwdriver **(B)**.

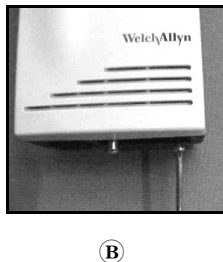
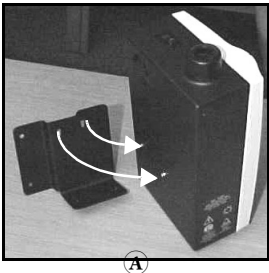

Table Mount

(Model #48859)

NOTE: Some exam table manufacturers supply mounting hardware for installation of the Exam Light III. Check with your table supplier for availability.

- Determine the side of the table that will be most optimal for mounting the light. Consideration should be taken as to the location of the nearest power outlet and patient traffic.

NOTE: Be sure that the mounting location is at least 10 inches (25.4 cm) below the table top cushion, and that the mounting position will not interfere with the operation of the table.

- Trace the outline of the mounting plate and mark the hole locations on a 1 inch (2.5cm) thick piece of plywood.
- Cut the piece of wood to the outline size and drill four .25 inch (.64cm) holes.
- Using the mounting plate as a template, mark the hole locations on the table and drill (4) .25 inch (.64 cm) holes in the table.
- Using four 8-32 x 2 inch (5.08 cm) screws with lock washers and nuts, install the block of wood and mounting plate to the table as shown in the diagram.
- To secure the Light Box to the mounting plate, insert two (2) .50" (1.27cm) screws through the bottom of the mounting plate and tighten into the bottom of the Light Box using a phillips head screwdriver.

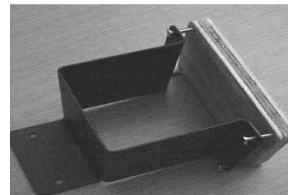

Mobile Stand

(Model # 48850)

Caster/Base Assembly Instructions **(A)**:

Push casters into the holes of the base until they "snap" into place. Alternate casters as shown.

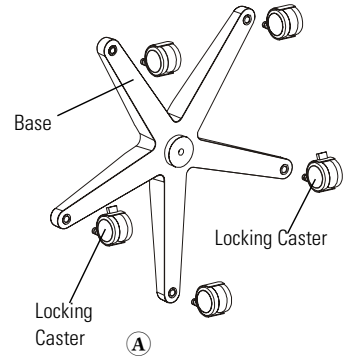

Base/Column Assembly Instructions **(B)**:

1. Insert column into center hole of base.
2. Insert .25 inch (.64 cm) lock washer, .75 inch (1.9 cm) flat washer and 1 1/4" (3.2 cm) socket head bolt into center hole. Tighten socket head bolt with hex socket wrench.

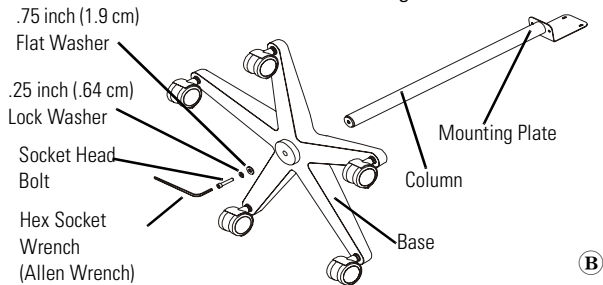

Exam Light/Mounting Plate Instructions **(C)**:

1. Place the keyhole pins on the back of the Exam Light into the slots on the top of the mounting plate and slide down.
2. Line up the screw holes on the bottom of the Exam Light with the screw holes on the mounting plate.
3. Insert the .50 inch (1.27 cm) screws through the bottom of the mounting plate and tighten with a phillips head screw driver (not included).

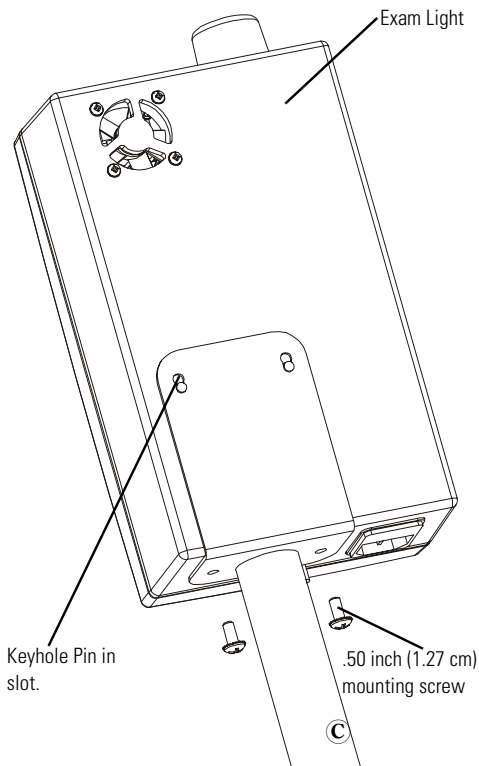

SET-UP AND OPERATION

Set Up

1. Secure the Light Box to one of the mounting options per the appropriate instructions.
2. Insert the Fiberoptic Light Pipe, Fiberoptic Light Cable, or Neonate Light Pipe into the light pipe receptacle on the top of the Light Box.
3. Plug the power cord into the base of the Light Box and the remaining end into a grounded AC outlet.
4. Toggle the light switch to the "ON" position to operate.

NOTE: Remember that the Fiberoptic Light Pipe, Fiberoptic Light Cable, and Neonate Light Pipe contain several thousand individual optical fibers, therefore appropriate handling is required to ensure long fiber life. Do not bend the flexible portions of the light pipe at acute angles as this will break individual fibers and reduce light transmission. For example, do not bend the semi-flexible middle portion of the Fiberoptic Light Pipe more than 180 degrees and do not bend the proximal and distal sections more than 90 degrees. Be careful not to pull on the Fiberoptic Light Cable as this may cause fibers to break.

Operation Of Light Pipe

The flexible portions of the Fiberoptic Light Pipe are designed to be articulated, but not twisted. Twisting or applying torque to the flexible sections will greatly decrease the life of the Light Pipe. This type of movement will cause premature drooping of the Light Pipe (will not stay in place once positioned) and eventually will result in breakage of the fiberoptic bundle. For best results, always position the Light Pipe by moving it in the same direction as gravity. For example, if the pipe needs to be raised, raise it above the desired position and then lower it into place.

NOTE: Upon manufacture, the Light Pipe is tested to assure maintenance of positioning and to verify the absence of noise upon articulation. Over a period of time and use, it is normal for the Light Pipe positioning capability to reduce and soften becoming less obedient. Abnormal softening or occurrence of noise upon articulation should be reported to Welch Allyn Technical Service (315-685-4560) immediately.

Operation of Focusing Sleeve

The focusing sleeve at the end of the Fiberoptic Light Pipe and Fiberoptic Light Cable provides adjustment of the illumination spot size. Twisting the knurled portion of the focusing sleeve in a clockwise direction will make the spot smaller. Twisting the knurled portion of the focusing sleeve in a counterclockwise direction will increase the spot size.

LAMP REPLACEMENT



CAUTION: Lamp may be hot. Allow the lamp to cool before replacing.

1. Turn the unit off and unplug the power cord from both the wall outlet and the Light Box.
2. Remove the unit from the patient area.
3. Using a screwdriver, loosen the single panel fastener that protrudes from the bottom of the unit. As the screw is loosened, there will be a noticeable "drop" as the front cover is released. **(A)**
4. Slightly lift the bottom of the front cover toward you and then slide the cover up to remove it. **(B)**
5. For initial lamp replacement only: Grasp wire clip at top of lamp. Rotate clip toward the base of the unit until it pops out. **(C)** Discard clip. It was for shipping purposes only.
6. Grasp the lamp connector and pull the lamp straight out of its holder. **(D)**
7. Pull the lamp from its connector and replace it with Welch Allyn Replacement Lamp #04200. **(E)**
8. Push the lamp back into the holder.
9. Attach the front cover by sliding the tabs at the top of the cover into the slots at the top of the back housing and then tightening the screw at the bottom of the unit.

10. Return the unit to the patient area and plug power cord back into bottom of unit and wall outlet.



Ⓐ



Ⓑ

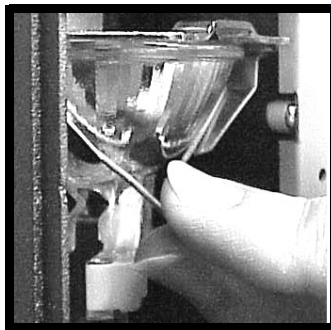

Ⓒ



Ⓓ

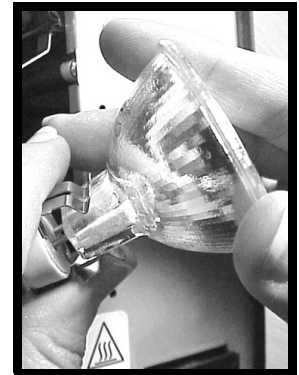

Ⓔ

FUSE REPLACEMENT

1. Turn the unit off and remove the power cord from both the wall outlet and the light box.
2. Press the tabs on both ends of the fuse drawer in and pull the fuse drawer out. Ⓐ
3. Remove and replace new fuses of the same type. There is no required orientation of the fuses. Be sure to replace both fuses. Ⓑ
4. Reinsert the fuse holder by pressing it into the power connector until it snaps into place.
5. If the new fuses blow, immediately contact Welch Allyn Technical Service (315-685-4560).

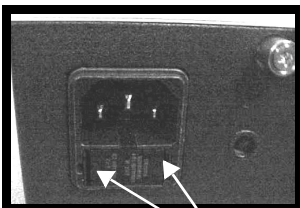

Ⓐ

Fuse Tabs

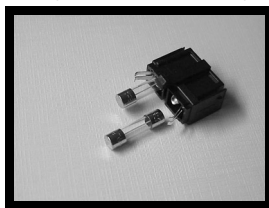

Ⓑ

CLEANING

Focusing Sleeve

For best results, use the disposable sheath model #52640.

1. Remove the focusing sleeve from the Fiberoptic Light Pipe or Fiberoptic Light Cable by rotating it counterclockwise to unthread.
2. Use a cotton swab soaked in warm water and mild detergent to clean the distal end of the Fiberoptic Light Pipe or Light Cable, the proximal side of the Focusing Sleeve (small end), and distal window on the large end on the Focusing Sleeve.
3. Dry using a new cotton swab.
4. Reassemble the Focusing Sleeve to the Light Pipe or Light Cable by rotating clockwise.

WARNING: Do not clean any part of the focusing sleeve with alcohol. Clean only with a mild detergent and water.

NOTE: The focusing sleeve should not be sterilized or immersed.

Fiberoptic Light Pipe, Light Cable, Neonate Light Pipe

For best results, use the disposable sheath model #52640.

External surfaces may be cleaned with a solution of warm water and mild detergent.

NOTE: The Fiberoptic Light Pipe, Light Cable, and Neonate Light Pipe should not be sterilized or immersed.

Light Box

Note: The Light Box should not be sterilized or immersed.

1. Prior to cleaning, turn power off and disconnect the power cord from both the wall outlet and the Light Box.
2. The external surfaces may be cleaned by wiping with a cloth dampened with mild soap and water or by using the following cleaning/disinfecting solutions. **DO NOT IMMERSE.**
 - 70% Isopropyl Alcohol
 - 10% mild bleach solution
 - 10% Iodine Based Solution

The power cord may be wiped clean using the same cleaning/disinfecting solutions listed above. Wipe dry with a clean cloth. Care must be taken not to get the prongs wet. **DO NOT IMMERSE.**

TROUBLESHOOTING

If lamp is not illuminating and...	Possible Cause	Solution
fan is not operating.	Light box is not plugged into either the wall outlet or the power cord socket.	Plug the power cord into the wall outlet and power cord socket at bottom of unit.
	Power switch is not turned on.	Depress the green side of the power switch.
	One or both fuses have blown.	Replace both fuses. Follow the instructions in the fuse replacement section. If fuses continue to blow, return Light Box to an authorized repair center.
	Power cord is damaged. This may cause intermittent operation.	Replace the power cord with a new Welch Allyn power cord.
	No power is supplied to the wall outlet.	Verify that the wall outlet has power by checking the circuit breaker status and by operating other equipment at that wall outlet.
fan is operating.	The lamp has burned out.	Replace with a new Welch Allyn lamp, model # 04200. Refer to the Lamp Replacement Section.
If light output seems low.	Lamp is not in optimal orientation.	Rotate lamp 90° in the lamp holder.

MAINTENANCE AND REPAIR

For minor trouble, refer to the troubleshooting section in this manual for possible causes and corrective action. Only qualified personnel should make electrical inspections of the Welch Allyn Light Box. To locate qualified personnel, contact your local authorized Welch Allyn distributor, or call Welch Allyn directly at 315-685-4560. Tampering with the unit will automatically void all warranties expressed or implied.

WARRANTY

Light Box - Welch Allyn guarantees that the Light Box is free of any manufacturing defects or Welch Allyn will repair or replace, free of charge, any parts proven to be defective through causes other than misuse, neglect, damage in shipment and normal wear and tear. The warranty is for a one year period from the original date of purchase.

Fiberoptic Light Pipe - The fiberoptic light pipe has been designed to not drift to a new position once positioned for an exam if the Light Box is mounted vertically according to the instructions. The warranty is for a one year period from the original date of purchase provided that the light pipe has not been tampered with or abused. Any Light Pipe that does not meet these performance requirements will be repaired or replaced at no charge to the customer.

SPECIFICATIONS

Electrical

Ref Model	Input	Output	Fuse
48740	120VAC~60Hz, 400mA	12VAC, 3.0A	T500mAL, 250V
48742	230VAC~50Hz, 250mA	12VAC, 3.0A	T315mAL, 250V
48744	230/240VAC~50Hz, 250mA	12VAC, 3.0A	T315mAL, 250V
48748	100VAC~50/60Hz, 500mA	12VAC, 3.0A	T630mAL, 250V

Power Cord

#18AWG, 3 wire grounded cord set, 8 feet (2.5 meters) long.

Physical Characteristics

Weight: 4.75 lb (2.16 Kg), light box only
Light Box H: 8.75 inches (22.23 cm)
Dimensions: W: 5.25 inches (13.34 cm)
D: 3.50 inches (8.89 cm)

Environment

Operating: 60°F (15°C) to 104°F (40°C), 75%
R.H. Max, 500 hPa - 1060 hPa Altitude
Transport/Storage: -4°F (-20°C) to 120°F (49°C), 95%
R.H. Max, 500 hPa - 1060 hPa Altitude

Equipment Classification

Class I, Continuous Operation

IPX0: Not protected against the ingress of water.

Approvals



IEC 60601-1, UL 2601-1, CAN/CSA C22.2 No 601.1, AS3200.1, IEC 60601-1-2



WELCH ALLYN AUSTRALIA PTY LTD
18-20 ORION ROAD
LANE COVE, NSW 2086
AUSTRALIA

EMC Framework of Australia

N344



The CE mark on this product indicates that it has been tested to and conforms with the provisions noted within the 93/42/EEC Medical Device Directive.

Authorized European Representative Address:

European Regulatory Manager
Welch Allyn Ltd.,
Kells Road, Navan,
County Meath, Republic of Ireland.
Tel.: 353-46-79060
Fax: 353-46-27128

NOTE: This product complies with current required standards for electromagnetic interference and should not present problems to other equipment or be affected by other devices. As a precaution, avoid using this device in close proximity to other equipment.

NOTE: This product contains no hazardous materials. Its disposal will not contaminate or harm the environment, or present any risk to individuals disposing of the product. As a precaution, it is recommended you contact your local disposal and/or recycling authority for information regarding the disposal of the equipment.